

Loglift 61 Z

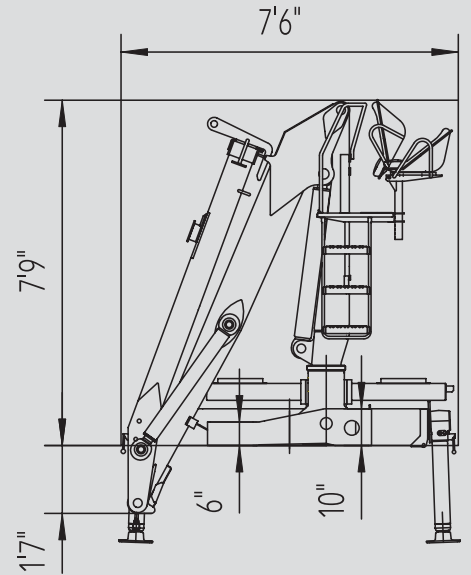

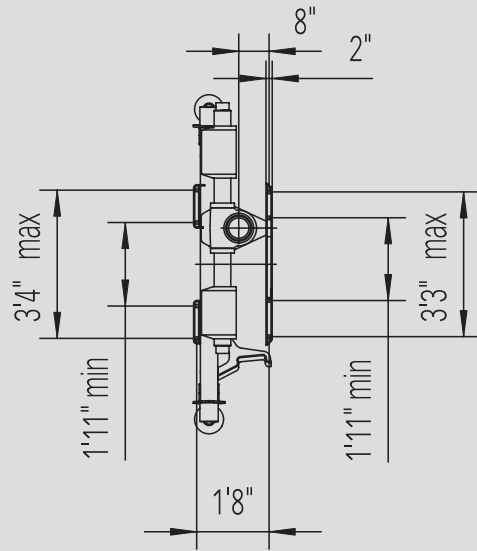

Capacity diagram

(Permitted load without lifting accessories)

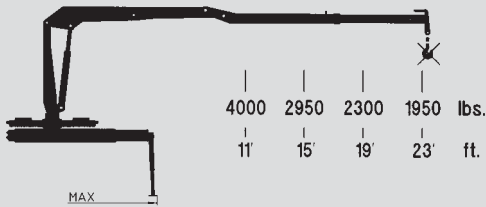

Outreach scheme

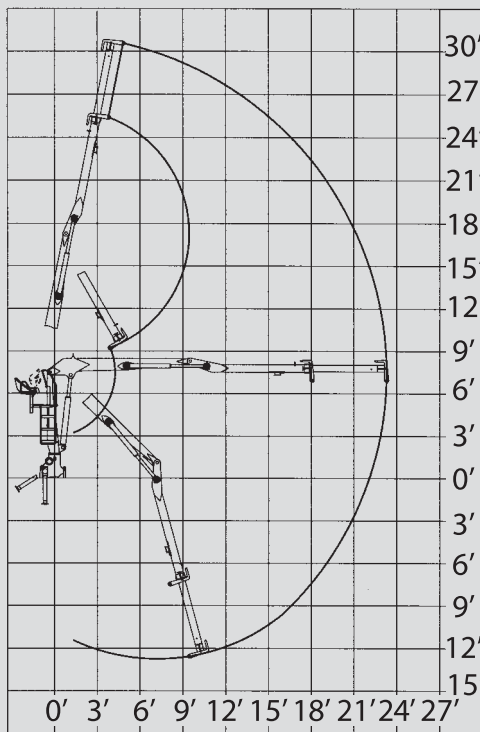

Hydraulic Log Loader Loglift 61 Z Specification			F 61 Z	
Lifting moment, gross	lbf.ft		56800	
Lifting moment, net	lbf.ft		44300	
Max. outreach	ft		23'4"	
Stroke of boom extension	ft		5'3"	
Slewing torque, gross	lbf.ft		10300	
Slewing angle	(degrees) ^o		415	
Road height	ft		7'9"	
Road width	ft		7'4"	
Weight without oil and grapple and with:				
	outriggers B	lbs	2820	
	outriggers C	lbs	2840	
Pump recommended	working pressure	psi	3190	
	oil flow	US gpm	1x16 / 2x13-16	
	power input	hp	31 / 52-62	
Equipment				
Rotators	models		MR 8 AF	GV 12-2
Slewing angle	unlimited ∞		∞	∞
Slewing torque (2900 psi)	lbf.ft		1180	1620
Weight	lbs		121	128
Log grabs	models		X26	X36
Jaw pressure (3190 psi)	lbf		2790	2590
Holding area	ft ²		2.7	3.8
Weight	lbs		375	385



A Hiab Company

Corporate Office: Hiab, Inc.
 12233 Williams Road, Perrysburg, Ohio 43551
 Tel: 419 482 6000 Fax: 419 482 6001
 e-mail: us.sales@hiab.com web: www.hiabus.com